

MODEL	BF-C1600-60
Standby Power (60Hz)	1500KW / 1875KVA
Prime Power (60Hz)	1250KW / 1562KVA

Standard Features

General Features:

- Engine (CCEC Cummins KTA50-G9)
- Radiator 40°C max, fans are driven by belt, with safety guard
- 24V charge alternator
- Alternator: single bearing alternator IP23, insulation class H/H
- Absorber
- Dry type air filter, fuel filter, oil filter, coolant filter
- Main line circuit breaker
- Permanent Magnet Generator (PMG)
- Standard control panel
- Four 12V batteries, rack and cable
- Ripple flex exhaust pipe, exhaust siphon, flange, muffler
- User manual



PHOTO FOR REFERENCE ONLY

Generator Ratings

Voltage	HZ	Phase	P.F (COS ϕ)	Standby Amps	Standby Ratings (KW/KVA)	Prime Ratings (KW/KVA)
480/277	60	3	0.8	2255	1500/1875	1250/1562
460/266	60	3	0.8	2353	1500/1875	1250/1562
440/254	60	3	0.8	2460	1500/1875	1250/1562
416/240	60	3	0.8	2602	1500/1875	1250/1562

Prime Power (PRP): Prime power is available for an unlimited number of annual hours in variable load application, in accordance with GB/T2820-97 (eqv ISO8528); A 10% overload capability is available for a period of 1 hour within a 12-hour period of operation.

Standby Power Rating (ESP): The standby power rating is applicable for supplying emergency power for the duration of a utility power interruption. No overload, utility parallel or negotiated outage operation capability is available at this rating.

Sales Promises

Baifa Power provides a full line of brand new and high quality products. Each and every unit is strictly factory tested.

Warranty is according to our standard conditions: a, 15 months, counted on the day BAIFA sold to the first buyer; b, One year after installation; c, 1000 running hours (accumulated); subject to the earlier one. Service and parts are available from Baifa Power or distributors in your location.

ENGINE DATA

Manufacturer / Model:	CCEC Cummins KTA50-G9, 4-cycle
Air Intake System:	Turbo, Air/Water cooling
Fuel System:	PT type fuel pump, EFC
Cylinder Arrangement:	16 in "V"
Displacement:	50.3L
Bore and Stroke:	159*159 (mm)
Compression Ratio:	13.9:1
Rated RPM:	1800rpm
Max. Standby Power at Rated RPM:	1656KW/2220HP
Governor Type:	Electronic

Exhaust System

Exhaust Gas Flow:	5025L/s
Exhaust Temperature:	515°C
Max Back Pressure:	7kPa

Air Intake System

Max Intake Restriction:	6.2kPa
Consumption:	2075L/s
Intake Flow:	L/s

Fuel System

100%(Prime Power) Load:	203 g/kWh
75%(Prime Power) Load:	210 g/kWh
50%(Prime Power) Load::	221 g/kWh
100%(Prime Power) Load::	318.6L/h

Oil System

Total Oil Capacity:	204L
Oil Consumption:	≤4g/kwh
Engine Oil Tank Capacity:	148~178L
Oil Pressure at Rated RPM:	345-483kPa

Cooling System

Engine Coolant Capacity:	174L
Thermostat:	82-93°C
Max Water Temperature:	104°C

ALTERNATOR SPECIFICATION**GENERAL DATA**

Compliance with GB755, BS5000, VDE0530, NEMAMG1-22, IED34-1, CSA22.2 and AS1359 standards.

Alternator Data

Number of Phase:	3
Connecting Type:	3 Phase and 4 Wires, "Y" type connecting
Number of Bearing:	1
Power Factor:	0.8
Protection Grade:	IP23
Altitude:	≤1000m
Exciter Type:	Brushless, self-exciting
Insulation Class, Temperature Rise:	H/H
Telephone Influence Factor (TIF):	<50
THF:	<2%
Alternator Capacity:	1690KVA
Alternator Efficiencies:	95.5%

GENERATING SET DATA

Voltage Regulation:	≥±5%
Voltage Regulation, Stead State:	≤±1%
Sudden Voltage Warp (100% Sudden Reduce):	≤+25%
Sudden Voltage Warp (Sudden Increase):	≤-20%
Voltage Stable Time (100% Sudden Reduce):	≤6S
Voltage Stable Time (Sudden Increase)	≤6S
Frequency Regulation, Stead State:	≤5%
Frequency Waving:	≤0.5%
Sudden Frequency Warp (100% Sudden Reduce):	≤+12%
Sudden Frequency Warp (Sudden Increase):	≤-10%
Frequency Recovery Time (100% Sudden Reduce):	≤5S
Frequency Recovery Time (Sudden Increase):	≤5S

Standard Features

- ◇ Baifa Standard Auto Control System
- ◇ Starting batteries (Maintenance-Free & Watering-Free) with connective wires
- ◇ Documents
- ◇ Permanent Magnet Generator(PMG)
- ◇ Exhaust System(including until muffler)
- ◇ Special tool for Cummins engine
- ◇ Oil Drain Valve

Options

- ◇ Daily Fuel Tank
- ◇ Battery Charger
- ◇ Engine Heater
- ◇ Water Separator
- ◇ Alternator Heater
- ◇ Soundproof Type
- ◇ Trailer Type
- ◇ Spare Parts
- ◇ Remote Control Panel
- ◇ Automatic Transfer Switch
- ◇ Paralleling System
- ◇ Switch box

Dimension & Weight

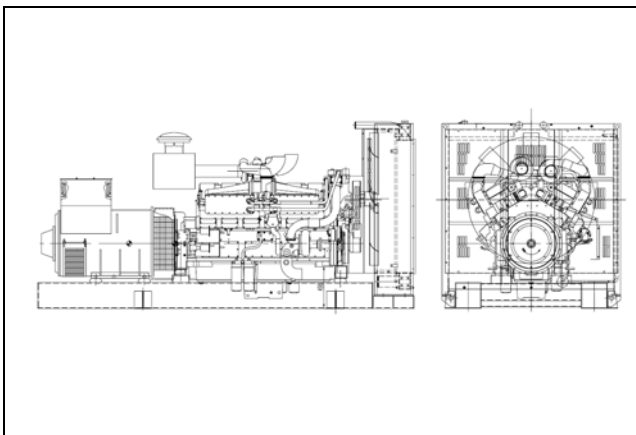

Standard Configuration (Open Type)

Overall Size: 4980×2200×2480 (mm)

Weight: 11000kg

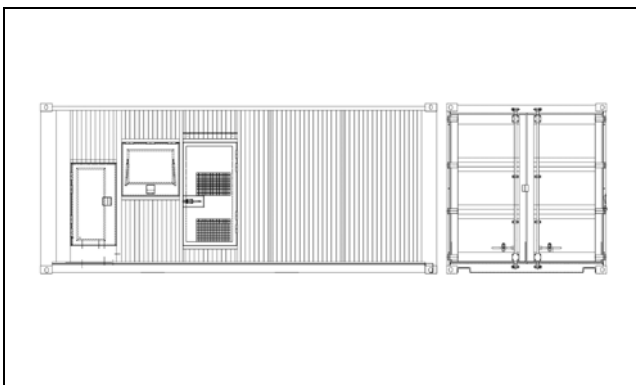

Soundproof Type (20'ft high container)

Overall Size: 6058×2438×2896 (mm)

Weight: 16500kg

Standard Control Panel



Baifa Standard Control Panel uses micro processing technique integrating digital, intelligent and network techniques which can carry out functions including auto start/stop, data measure, alarming. The controller uses LCD display, optional Chinese and English display interface with operation easy and reliable. It can be widely used in all types of generator automatic control system for compact structure, advanced circuits, simple connections and high reliability

Auto Module Control Panel



Auto Module Control Panel is the configuration for nobody on duty controlling generators. This kind of panel adopts auto module control system, with large LCD display to show the menu. Features: MRS10-can receive remote output signal from ATS and realize auto start and stop of generators. MRS16-can realize all functions of MRS10, add RS232 interface which can communicate with PC to realize remote operation. AMF25-Auto Mains Failure controller, can realize all functions of MRS16, furthermore can detect ATS and control directly.

Auto Parallel Control Panel



Automatic Parallel Control Panel This new automatic parallel system adopts intelligent modules, inserted and folded installed, no need the peripheral relay and logic circuit. The main switch adopts electronic breaker or frame breaker, combined together with the generator, which is very reliable. One generator, one panel. The panel can be used both for singly and parallel. It is only need to parallel generator with such panel when the capability needs to be enlarged in the future.